

Kemet

PRECISION LAPPING AND POLISHING SYSTEMS

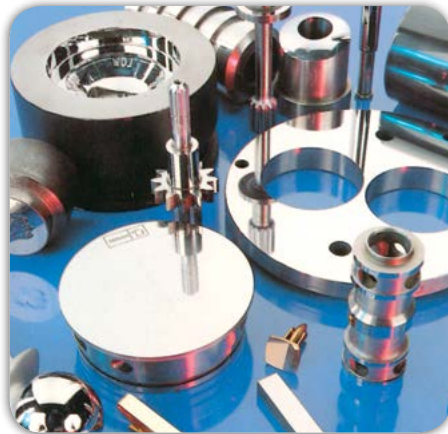

Contents

MACHINES

1-12

15" to 120" Lapping Machines	1-5
Spherical Lapping	6
Chemical Mechanical Polishing	7-8
Internal Lapping	8
Match Lapping	9
Dual Face Lapping	10
Geological Thin Section Lapping	11-12
Specialist Lapping Machines	12

CONSUMABLES

13-22

Lapping Plates	13-15
Conditioning Rings	14
Cast Iron Plates	15
Liquid Diamond	15-16
Diamond Compound / Paste	17
Lubricating Fluids	17
Lapping Oil	17
Conventional Abrasives	18-19
Abrasive Pastes & Powders	19
Lapping Film	19-20
Diamond Grinding Cloths	20
Polishing Pads / Cloths	21
Workholding & Fixtures	22
Polishing Stand with Paper	22

ACCESSORIES

23-26

Dispenser Systems	23-24
Lapping Machine Maintenance	24
Flatness Measuring Equipment	24-25
Portable / Hand Lapping Kits	26

CLEANING & TECHNICAL SUPPORT

27-31

Ultrasonic Cleaners	27-28
Lapping Service	29
Kemet Technical Support	30
Flat Lapping Q&A	31



Kemet

Ordering Information

Telephone:

+44(0)1622 607507

Sales Desk - Direct Line

+44(0)1622 755287

Enquiries & Technical Support

Email:

sales@kemet.co.uk

Website:

www.kemet.co.uk

Fax:

+44(0)1622 670915

Post

Kemet International Ltd

Cuxton Road, Parkwood Trading Estate,
Maidstone, Kent ME15 9NJ, UK

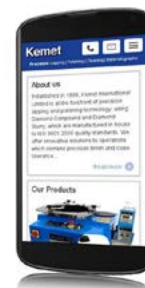

Precision Lapping Services at
Great prices, even for small
volumes





Kemet Precision Lapping and Polishing Systems

Since 1938, Kemet has been at the forefront of precision polishing technology, producing diamond pastes, slurries and composite lapping/polishing materials in our purpose built facilities strictly manufactured to ISO 9001:2015 quality standards.

Kemet Precision Lapping and Polishing Systems offer the most efficient and reliable method of producing precise surface geometry and finish whether flat, contoured or spherical. Our machines and systems are at the forefront of today's advanced lapping technology, especially when used with Kemet Diamond products. Kemet Diamond quality and grading enables reliable precision lapping to be performed in production situations.

Now a truly international organisation, Kemet's activities span the world, spearheaded by companies in nine countries, all sharing the same commitment to customer support. This, along with more than 80 years' experience, means Kemet are here to provide you with the technical support to overcome all your lapping, polishing and cleaning challenges.

Industries and Applications

Aerospace

Pumps and Valves
Turbine Parts
Engine Assemblies
Spacers

Technical Ceramics

Alumina - Zirconia
Silicon Carbide
Piezo Ceramics
Ferrite

Data Storage

Disc Drive Heads
CD Moulds
Laminations
Smart Phones

Tool and Die

Moulds and Inserts
Printing Plates
Slitter Knives
Extrusion Dies

Electro Optics

Plano Optics
Laser Rods and Prisms
Fibre Optics
Sensors
Sapphire
ALN

Automotive

Diesel Injectors
Airbag Initiators
Piston Rings
Fuel Pumps

Pumps & Valves

Fuel Pumps
Hydraulic Pumps
Mechanical Seals
Gate Valves

Medical Devices

Fibre Scopes
Surgical Instruments
Hip and Knee Joints
Pacemaker Parts



Lapping Machines

Kemet's Advanced Lapping Technology

Kemet offers a comprehensive range of standard lapping and polishing systems for use across all industrial sectors. Special purpose machines can also be developed for specific applications.

Benefits:

- Faster polishing process
- One operation surface finish
- Faster material removal
- Pre set parameters
- Reduced rejections
- Semi skilled operation
- Significant reduction in lapping costs
- Reduced inspection requirements
- Optimum geometry and surface finish
- Better utilisation of machine time
- Cleaner environment conditions

Lapping Machine Options



Open Face

The open face machines are for use where work pieces are either large in size and can be lapped under their own weight or where pressure application by hand weights is sufficient.



Pneumatic Lift

The pneumatic lift machines will raise and lower the weights and also apply pressure where necessary. All are fitted with mandatory safety controls.

Kemet Lapping Machine Capacity Chart

Components per conditioning ring based on typical loading of approximately 60% ring surface area.

Machine Model (No of Rings)	Diameter of Parts (mm)																									
	6	7.5	9	10.5	12	13.5	15	18	22	26	30	34	38	42	46	50	54	60	70	80	90	100	110	120	130	140
15 (3 Rings)	275	175	118	86	60	50	40	27	18	12	10	8	6	5	4	3	2	2	2	1	1	1	1	1	1	1
20 (3 Rings)	-	-	-	-	150	114	90	63	39	33	21	17	14	10	9	7	6	5	3	3	2	2	1	1	1	1
24 (3 Rings)	-	-	-	-	210	165	132	87	57	42	33	24	18	15	13	10	9	7	5	4	3	3	2	2	1	1
24 (4 Rings)	-	-	-	-	150	114	90	63	39	33	21	17	14	10	9	7	6	5	3	3	2	2	1	1	1	1
36 (3 Rings)	-	-	-	-	-	-	-	204	93	93	69	60	42	33	29	24	21	17	12	10	7	6	5	4	3	2
36 (4 Rings)	-	-	-	-	-	-	-	156	72	72	54	39	33	25	33	20	15	12	10	8	5	5	3	2	2	2
48 (4 Rings)	-	-	-	-	-	-	-	-	132	132	99	75	60	48	39	33	29	24	17	14	12	8	7	5	5	4
56 (4 Rings)	-	-	-	-	-	-	-	-	204	204	150	117	100	76	62	52	44	35	26	20	16	12	10	8	8	6
72 (4 Rings)	-	-	-	-	-	-	-	-	-	-	-	204	164	132	108	92	78	62	44	35	26	21	18	16	14	10
84 (4 Rings)	-	-	-	-	-	-	-	-	-	-	-	-	-	185	152	129	109	88	63	47	38	30	24	20	17	15

The above data is for using standard loading procedures. It is often possible to extend the capacity of a machine utilising special workholding arrangements and fixtures.

Conditioning Ring Spec		Machine Model								
		15	20	24	36	48	56	72	84	120
Inside Diameter (mm)	3 Rings	140	191	248	368	505	578	-	-	-
	4 Rings	-	-	209	322	432	530	692	813	1016

Kemet 15/20 Models

The bench-mounted Kemet 15 and 20 Lapping Machines have a rigid metal construction with a height-adjustable worktable. The machines incorporate a digital Process Timer and a fully automatic Liquid Diamond Dispensing System.

Features & Benefits:

- Variable speed
- Bench mounted
- Produces optically flat surfaces with high precision surface finish
- Fully controllable Kemet Electronic Dispensing System accurately meters diamond abrasive onto the lapping plate - Reduces lapping costs
- Only small quantities of diamond abrasive and non-toxic fluids are used - Reduces waste
- Built in abrasive system for conditioning Kemet Composite Plates
- Easily transportable
- Electrical System complies with EN 60 204
- Easy to adapt for special lapping applications



Options:

- Lift off disc system on model 15"
- Fixed speed
- Pneumatic lift on model 20"

Other Versions:

- Col-K Chemical polishing version (see page 7)
- Clipper Blade sharpening machine

Recommended Accessories	Machine Model	
	15	20
Cast Iron Conditioning Rings - Solid - Set of 3	360204	360818
Cast Iron Conditioning Rings - Serrated - Set of 3	360203	361027
Zytel Roller Bearing Assemblies - Set of 6	360212	360212
O-rings for Zytel Bearings - Set of 6	360270	360270
Flatness Gauge	361304	

Recommended Consumables	Machine Model	
	15	20
Cast Iron Serrated Lapping Plate (Pre-lapped)	362400	362402
Cast Iron Solid Lapping Plate (Pre-lapped)	362401	362403
Kemet Copper Lapping Plate	351102	351103
Kemet Copper SP2 Lapping Plate	351159	351964
Kemet Iron Lapping Plate	351002	351081
Kemet PR3 Lapping Plate	351340	351374
Kemet Tin Lapping Plate	351305	351320
Kemet XL Lapping Plate	351356	351375
Kemet XP Lapping Plate	351202	351266

Huge range of other accessories and consumables available for the Kemet 15 & 20 Models

Machine Model	15	20
Lapping Plate outside Diameter	381 mm	508 mm
Lapping Plate Speed	70 rpm	70 rpm
No. of Conditioning Rings	3	3
Conditioning Ring inside Diameter	140 mm	191 mm
Max load per Conditioning ring	39 Kg	53 Kg
Height of Open Face Machine	670 mm	700 mm
Height of Pneumatic Lift Machine	N/A	965 mm
Working Height	310 mm	385 mm
Depth of Machine	660 mm	780 mm
Width of Machine	760 mm	883 mm
Standard Electrical Supply	220v-1Ph-50Hz or 380v or 415v 3Ph-50Hz	
Main Drive Motor	0.37 kW	0.75 kW
Abrasive pump motor	0.18 kW	0.18 kW
Approx. Weight	Open Face	136 kg
	Pneumatic	N/A
		200 kg
		385 kg

Lift Off Disc System	Machine Model
	15
Aluminium Drive Plate	361002
Aluminium Lift Off Disc	361001
Kemet Iron Lift Off Disc	351025
Kemet Copper Lift Off Disc	351121
Kemet XP Lift Off Disc	351226
Kemet Tin Lift Off Disc	351314

Kemet 24/36 Models

Both Kemet 24 and 36 machines have rigid welded tubular section steel frames, supporting the gearbox, drive motor and worktable. With the option of a diamond dispensing system they also house an integral abrasive compound feed and waste tanks behind lift-off panels. The Kemet 36 machine incorporates a soft starting feature, which smoothly accelerates the Kemet Composite or cast iron lapping plate from stand still to full speed (optional extra for Kemet 24).



Features & Benefits:

- Produces optically flat surfaces with high precision surface finish
- Fully controllable Kemet Electronic Dispensing System accurately meters diamond abrasive onto the Kemet Composite Lapping Plate, reducing lapping costs and waste
- Built in abrasive system for conditioning Kemet Composite Lapping Plates
- Suitable for large parts or large volume production
- Electrical System complies with EN 60 204

Options:

- Variable speed up to 70 rpm
- Temperature control (water cooled plates)
- 3 or 4 conditioning rings
- Col-K chemical polishing versions
- Light curtain or full Perspex guarding available

Option	Open Face		Pneumatic Lift		
Machine Model	24	36	24	36	
Height	920 mm	960 mm	1925 mm	1960 mm	
Working Height	-	-	1150 mm	1270 mm	
Width	1200 mm	1435 mm	1240 mm	1505 mm	
Depth	1350 mm	1640 mm	1350 mm	1640 mm	
Approx. Weight	575 kg	1165kg	700kg	1250kg	
Lapping Plate outside Diameter	610 mm	914 mm	610 mm	914 mm	
Lapping Plate Speed	58 rpm	58 rpm	58 rpm	58 rpm	
N° of Conditioning Rings	3 or 4	3 or 4	3 or 4	3 or 4	
Conditioning Ring inside Diameter	3 ring	248 mm	368 mm	248 mm	368 mm
	4 ring	210 mm	322 mm	210 mm	322 mm
Max load per Conditioning ring	3 ring	250 Kg	350 Kg	250 Kg	350 Kg
	4 ring	200 Kg	300 Kg	200 Kg	300 Kg
Main Drive Motor	1.5 kW	4 kW	1.5 kW	4 kW	
Abrasive pump motor	0.18 kW	0.18 kW	0.18 kW	0.18 kW	
Air Requirements	4 Bar min	4 Bar min	4 Bar min	4 Bar min	
Standard Electrical Supply	220v or 380v or 415v 3Ph-50Hz				

Electronic Dispensing Equipment Standard on all above Models (see page 21)

Kemet 40 also available with Kemet Lapping Plate outside diameter 1016mm. Three cast iron serrated conditioning rings, inside diameter 406mm.

Recommended Accessories	Machine Model	
	24	36
Cast Iron Conditioning Rings - Solid for 3 Ring Machine - Set of 3	360679	360186
Cast Iron Conditioning Rings - Serrated for 3 Ring Machine - Set of 3	360208	360278
Cast Iron Conditioning Rings - Solid for 4 Ring Machine - Set of 4	360680	360681
Cast Iron Conditioning Rings - Serrated for 4 Ring Machine - Set of 4	360274	360682
Zytel Roller Bearing Assemblies - Set of 6	360214	360259
O-rings for Zytel Bearings - Set of 6	360672	360270
Roller Bearing Assemblies - Set of 6	360213	360259
O-rings for Roller Bearings - Set of 24	*	360659
Flatness Gauge	361304	

Recommended Consumables	Machine Model	
	24	36
Cast Iron Serrated Lapping Plate (Pre-lapped)	362404	362406
Cast Iron Solid Lapping Plate (Pre-lapped)	362405	362407
Kemet Copper Lapping Plate	351106	351124
Kemet Copper SP2 Lapping Plate	351177	351965
Kemet Iron Lapping Plate	351006	351010
Kemet PR3 Lapping Plate	351357	351343
Kemet Tin Lapping Plate	351306	351315
Kemet XL Lapping Plate	351376	351377
Kemet XP Lapping Plate	351206	351227

Huge range of other accessories and consumables available for the Kemet 24 & 36 Models
* Available on request

Kemet 48/56 Models

These Precision Diamond Flat Lapping & Polishing Machines, are available as open face and pneumatic lift with a diamond dispensing system. Equipped with a serrated lapping plate consisting of 16 segments* for the Kemet 48 and 24 segments for the Kemet 56, the individual cast iron segments are faced with Kemet Composite material bolted to a support plate.

* Solid plate option available for Kemet 48"

Option	Open Face		Pneumatic Lift	
	48	56	48	56
Machine Model	48	56	48	56
Height (H)	1010 mm	1030mm	2350 mm	2260 mm
Working Height (WH)	-	-	1390 mm	1400 mm
Width (W)	1510 mm	1700 mm	1510 mm	1700 mm
Depth (D)	2000 mm	2020 mm	2520 mm	2520 mm
Approx. Weight	3400 kg	4100 kg	4000 kg	5000 kg
Lapping Plate outside Diameter	1219 mm	1422 mm	1219 mm	1422 mm
Lapping Plate Speed	48 rpm	48 rpm	48 rpm	48 rpm
Conditioning Ring inside Diameter	3 ring	505 mm	505 mm	578 mm
	4 ring	432 mm	432 mm	530 mm
Max load per Conditioning ring	3 ring	375 Kg	375 Kg	400 Kg
	4 ring	325 Kg	350 Kg	350 Kg
Main Drive Motor	7.5 kW	11 kW	7.5 kW	11 kW
Abrasive pump motor	0.18 kW	0.18 kW	0.18 kW	0.18 kW
Abrasive Tank capacity	115 Litres	115 Litres	115 Litres	115 Litres
Waste tank capacity	37 Litres	37 Litres	37 Litres	37 Litres
Standard Electrical Supply	220V or 380V or 415V 3 Ph 50Hz			

Features & Benefits:

- Higher capacity
- 3 or 4 conditioning rings
- Heavier and larger parts (up to 505 mm for Kemet 48 and 578 mm for Kemet 56)
- Water cooling option available

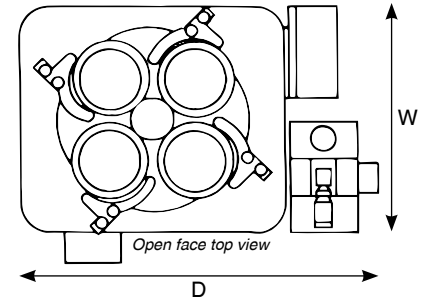
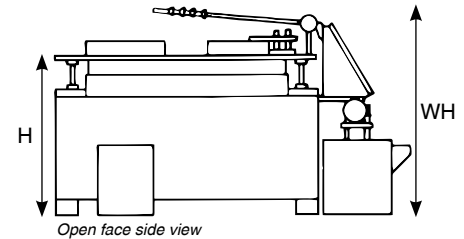

Recommended Accessories	Machine Model	
	48	56
Cast Iron Conditioning Rings - Solid for 4 Ring Machine - Set of 4	360235	360749
Cast Iron Conditioning Rings - Solid for 3 Ring Machine - Set of 3	360662	*
Cast Iron Conditioning Rings - Serrated for 4 Ring Machine - Set of 4	360642	*
Cast Iron Conditioning Rings - Serrated for 3 Ring Machine - Set of 3	360833	360910
Roller Bar Bearing Assembly	360729	360869
Flatness Gauge	361304	

Recommended Consumables	Machine Model	
	48	56
Cast Iron Segments for 3 Rings - Set of 16	360265	361860
Cast Iron Segments for 4 Rings - Set of 16	360776	362216
Kemet Iron Lapping Plate (For 3 Rings)	351161	351170
Kemet Copper Lapping Plate (For 3 Rings)	351174	*
Kemet Copper SP2 Lapping Plate (For 3 Rings)	*	*
Kemet Iron Lapping Plate (For 4 Rings)	351042	351183
Kemet Copper Lapping Plate (For 4 Rings)	*	*
Kemet Copper SP2 Lapping Plate (For 4 Rings)	*	*

Huge range of other accessories and consumables available for the Kemet 48 & 56 Models

* Available on request

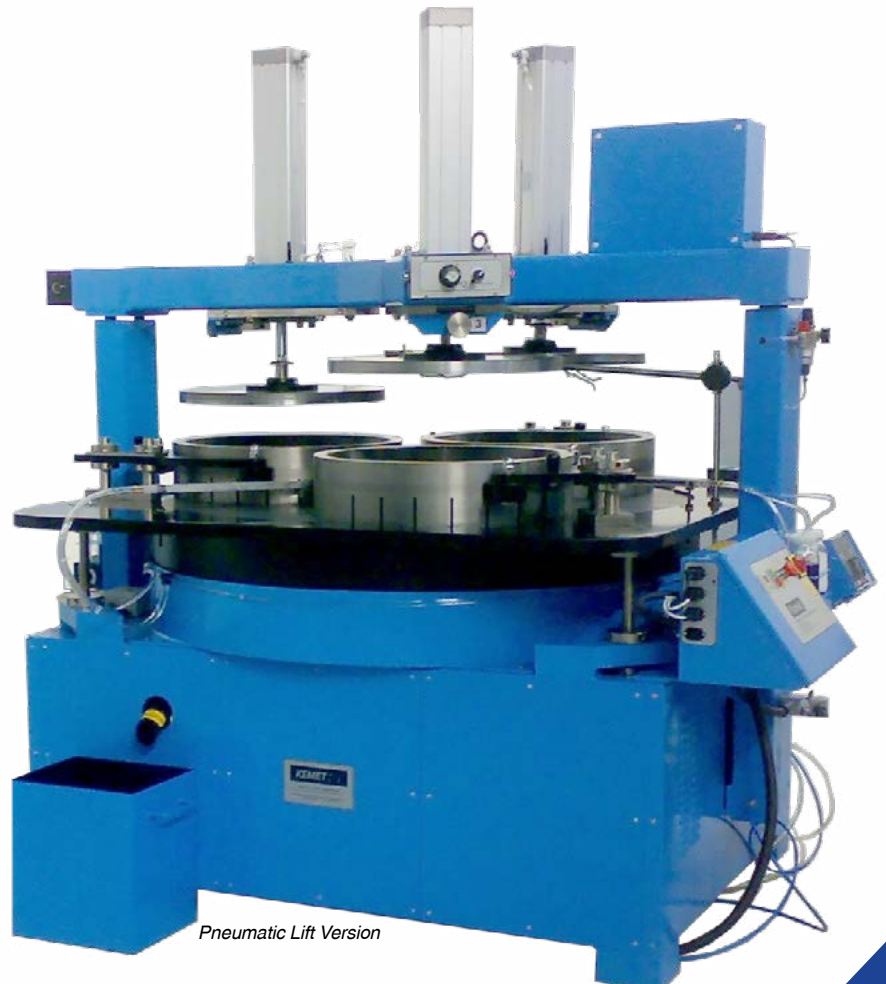

Kemet 72/84/120 Models

For larger lapping applications Kemet offer machines with a 72", 84" or 120" segmented plate, in high density cast iron or faced with Kemet composites.

Features & Benefits:

- Set within a mesh guard, a side mounted motor transmits the drive via multiple v-belts to a mechanical reduction gearbox at the centre of a cruciform shaped steel structure.
- Four stations, the roller yokes mounted on hollow section upright columns at the end of each arm, which also support the trough around the lap plate.
- Electronic soft start to smooth accelerate the lap plate to full speed is time adjustable to suit individual process conditions.
- Suitable for use with conventional abrasive slurries or Kemet Diamond slurries.
- Electronic diamond dispenser and stirrer unit provides fully controlled metering of liquid diamond and lubricating fluid to each station, via dispensing bars and spray heads, to ensure even distribution and minimise consumable costs and waste.
- Free-standing conventional abrasive reservoir/stirrer/pump supplies four individually adjustable feeds to each of the stations.
- Water cooling option available



Open Face Version

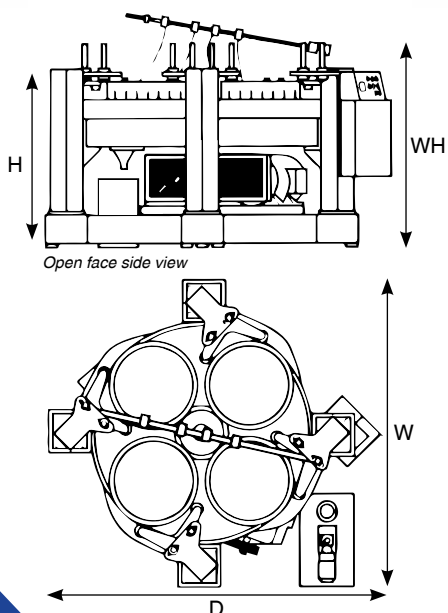

Option	Open Face			Pneumatic Lift		
	72	84	120	72	84	120
Machine Model	72	84	120	72	84	120
Approx. Height (H)	1350 mm	1500 mm	*	2764 mm	*	*
Working Height (WH)	-	-	-	*	*	*
Approx. Width (W)	3026 mm	2600 mm	*	3026 mm	2600 mm	*
Approx. Depth (D)	3073 mm	2600 mm	*	3073 mm	2600 mm	*
Approx. Weight	6000 kg	9000 kg	*	10000 kg	12000 kg	*
Lapping Plate outside Ø	1829 mm	2134 mm	3000 mm	1829 mm	2134 mm	3000 mm
Approx. Lapping Plate Speed	30 rpm	20 rpm	18 rpm	36 rpm	20 rpm	18 rpm
No. of Conditioning Rings	4	4	4	4	4	4
Conditioning Ring inside Ø	692 mm	813 mm	1025 mm	692 mm	813 mm	1025 mm
Max load per Conditioning ring	2000 Kg	2250 Kg	*	2000 Kg	2250 Kg	*
Main Drive Motor	15 kW	30 kW	*	15 kW	30 kW	*
Abrasive pump motor	0.18 kW	0.18 kW	0.18 kW	0.18 kW	0.18 kW	0.18 kW
Abrasive Tank capacity	117 Litres	117 Litres	132 Litres	117 Litres	117 Litres	132 Litres
Waste tank capacity	37 Litres	37 Litres	57 Litres	37 Litres	37 Litres	57 Litres
Standard Electrical Supply	220V or 380V or 415V 3 Ph 50Hz					

* Designed to customer specification

KemiSphere - Bench Top Spherical Lapping Machine

The KemiSphere is a small single station spherical lapping and polishing machine ideal for either matching 2 spherical forms together or, with appropriate tooling, it has the ability to lap and polish spherical forms to better than 5µm roundness with a mirror finish. It's a perfect replacement for jobs currently hand lapped together, and its bench top design makes it a useful addition to any workshop involved in spherical lapping.

Features & Benefits:

- 3 motors with independent variable speed control
- Simple tooling change
- HMI control with 20 programme memory
- Low running costs
- Manual and jog facility provided for setting
- Fully guarded with interlocks and safety circuit
- Single button process start
- Eye level controls
- Dimensions 480 (W) x 628 (D) x 971 (H) mm
- CE marked. Electrical supply 230V-single phase-50Hz
- Sweep setting from 0-45 degrees fully adjustable
- Clock wise and counter clockwise rotation of lap motor
- Digital Timer
- Product code: 359875



Kemet Spherical Lapping Machine

The Kemet Spherical Lapping Machine laps and polishes pre-machined spherical balls and cups to a mirror finish with the capability of achieving roundness better than <3 microns.

Features & Benefits:

- 6 motors all with independent variable speed to provide complete control
- Size: 1600 (W) x 820 (D) x 2500 (H) mm
- Lapping and polishing pressures applied pneumatically
- Average process time less than 5 mins
- Simple change from ball to cup polishing action
- Manual and jog facility provided for setting up
- Fully guarded with auto lifting door access
- Comes complete with initial tooling set
- Full manual and training provided
- Low running costs
- Dual process timers
- Single button process start
- Lighting provided
- Smooth and silent running
- CE marked. Electrical supply 230V-single phase-50Hz or 110V-single phase-60Hz
- Air: 3 bar max
- Product code: 360061



Orthopaedic Hip Ball polished with Spherical Lapping Machine



KemCol - Super Finishing Machines

The KemCol Super Finishing machines are based on the popular Kemet range of lapping and polishing machine, but incorporate stainless steel elements in place of painted components for longer life, and contamination free polishing. They come as standard with an integrated Kemet aKu-Disp fully programmable peristaltic pump system, and either ceramic faced, or stainless steel conditioning rings. The machines are ideal for chemo mechanical polishing and Cerium Oxide based polishing applications. Cerium oxide suspensions and powders available upon request.



Machine Model	15	20	24
Height (mm)	400	700	920
Working Height (mm)	310	385	-
Width (mm)	800	883	1200
Depth (mm)	650	780	1350
Nett Weight (kgs)	90	200	575
Polishing Pad Diameter (mm)	380	508	610
No of conditioning rings	3	3	3 or 4
Inside diameter of conditioning rings (mm)	140	191	248
Main Motor (kW)	0.37	0.75	1.5
Product code	359876	359872	*



Mirror Finish

Features & Benefits:

- Stainless steel worktable surrounding polishing pad
- Polished stainless steel yokes for easier cleaning
- Stainless steel drive plate
- Aluminium lift off disc system optional
- Ceramic faced or stainless steel conditioning rings for contamination free polishing
- aKu-Disp fully programmable peristaltic pump unit fitted as standard
- Suitable for Kemet magnetic polishing pad system for easy pad change

Col-K Polishing Media	5 litres	10 litres	20 litres
Col-K	600212	600238	600204
Col-K (NC)	600199	600239	600202

aKu-Disp Spares	Code
Spare Peristaltic Head Unit with Tube	362520
aKu-Disp Feedarm	362514
Spare Tubing (1 meter)	363109

Recommended Accessories	Machine Model		
	15	20	24
Set of 3 Ceramic Faced Conditioning Rings	361522	361982	361528
Stainless Steel Plastic Faced Conditioning Rings	362235	361874	361539
Stainless Steel Support Plate (For Polishing Pads)	362033	*	*
Aluminium Lift Off Disc	361001	362290	-
Aluminium Drive Plate	361002	362255	-
Thin Metal Disc (For use with magnetic system)	342563	*	*
Magnetic Disc	345773	*	345774

Recommended Consumables	Machine Model		
	15	20	24
CHEM-H Polyurethane Polishing Pad	341865	341789	341786
PSU-M Chemo-Textile Cloth for Cerium	341011	341059	341012
MRE Short Napped Final Polishing Pad	341715	*	341877

The aKu-Disp is designed to work in conjunction with the lapping machine. It links to the machines main timer system and the stirrer function operates as soon as power is on the unit and has manually operated variable speed controls for both the pump and stirrer. More details of the aKu-Disp on page 24.



* Available on request

Kemet DiaCol - Lapping / Polishing / Super Finishing Machine

The Kemet DiaCol has been developed as a single machine that is able to lap and polish components using the complete range of processes from conventional lapping with a cast iron plate and aluminium oxide or silicon carbide slurries, precision diamond lapping and polishing with a Kemet composite lapping plate and Kemet's diamond slurries and super finishing CMP (Chemo Mechanical polishing) using a CHEM-H pad and COL-K polishing media. Machine available in 15", 20" and 24".

Features & Benefits:

- Stainless Steel adjustable worktable, conditioning ring, roller bearing assemblies and pressure weights
- Epoxy coated support plate
- Conventional abrasive system
- Kemet Diamond dispensing system and stirrer
- Ceramic faced or stainless steel conditioning rings for contamination free polishing
- Kemet AkuDisp fully programmable peristaltic pump unit fitted as standard
- Suitable for Kemet magnetic polishing pad system for easy pad change

Up until now, Kemet machines have been able to run both conventional and diamond processes, but any CMP polishing required a separate machine. This is because the CMP polishing process is corrosive. The DiaCol overcomes all these challenges for longer life and contamination free polishing with the parts that come into contact with COL-K being either epoxy coated, stainless steel, or aluminium.



Product	Code
Kemet DiaCol 15	359867
Kemet DiaCol 20	359859
Kemet DiaCol 24	359869

Kemet Internal Lapping Machine

The Internal Lapping Machine has been designed to accurately lap internal valve faces. This lapping machine will process internal faces up to 300mm (3" to 16") in diameter, producing a flatness of 0.001mm. Depending on the material and the tooling, anything from a standard matt finish to a high mirror polish can be obtained. The Kemet Internal Lapping Machine can quickly be changed to a standard lapping machine, allowing the flatness of the laps, which generate the flatness of the recessed internal face, to be maintained on the same machine. This means that a single machine can produce the required flatness on the lap tooling and then generate the same flatness on the internal faces, a bonus in terms of cost and footprint.

Features & Benefits:

- Bespoke holding plate designed to customer/component requirements
- Includes full set of laps to suit application
- Variable Speed up to 70 rpm
- Capable of processing valves from 3" - 16"
- Short process times & easy to use
- Integrally mounted high torque drive unit with 0.37kW (0.5HP) motor
- Sealed maintenance free reduction gearbox
- Electronic digital timer with variable time ranges
- Yoke arm which can apply additional pressure when required
- Electrical: 230V-single phase-50Hz
- Product code: 359706



Kemtech Spherimatch - Match Lapping Machine

The Kemtech Spherimatch provides an automated method to match lap two valve halves, or similar components, together: For example - matching the concave barrel of a hydraulic piston pump to its convex swash plate. These faces need a perfectly matching radius to maintain performance and minimise leakage.

The Spherimatch enables the removal of even deep scoring and final match lapping of bodies up to 400mm high and ranging from 75mm diameter up to 250mm.



Specification

- Match laps parts from 75 to 250mm diameter and up to 400mm high
- Fabricated steel body with adjustable levelling feet
- Heavy duty adjustable worktable
- Integrally mounted high torque drive unit with 0.37kW (0.5HP) motor
- Sealed maintenance free reduction gearbox
- Electronic digital timer with variable time ranges
- 3 jaw chuck
- Lap plate speed variable up to 70 rpm
- Variable speed sweep action
- Electrical: 230V-single phase-50Hz or 110V-single phase-60Hz
- Initial supply of lapping abrasives included along with full instructions in their use
- Product code: 359599

With a fully programmable process timer, this versatile machine can match lap curved or flat surfaces, of the same or different materials, with variable rotation speeds up to 70 rpm and a range of sweep arm strokes and speeds to suit the components being lapped.

Used in combination with Kemet's diamond compounds and conventional aluminium oxide pastes, the Spherimatch is an essential tool for any hydraulic servicing centre.

Kemet offer free tests complete with a full test report showing process times and stages for each pair of parts.



Match lapped 125mm piston pump body and swash plate

One component part is held in a fully guarded, three jaw chuck with reversible jaws and the opposing part located under the sweep arm with a specially designed location and anti-rotation fixture. Pressure is applied to the top part being lapped.

Kemtech Twin Lap 50 & 120 - Dual Face lapping

The Kemet Twin Lap machine is a small but versatile bench mounted machine ideally suited for small workshops and laboratories. It comes fully equipped and ready to use and is suitable for lapping components up to 52mm diameter (2") and up to 10mm thick. In certain circumstances larger components can be accommodated.

Technical Specifications - Twin Lap 50	
Height	600mm
Depth	785mm
Width	830mm
Capacity	Ø174.45mm (6.8") lapping plate, solid or serrated. Ø52mm (2") maximum part diameter
Nett Weight	170kg (includes plate and accessories)
Max Component Mass	20 Kg
Standard Tooling	Cast iron, lap plate Grade 300 Ø174.45mm (6.8") OD x Ø87.3mm (3.43") ID x 13mm (0.51") thick 5mm usable
Electrical supply	1 phase, 50/60 Hz, 110 or 230 volts
Product code	359857



The machine is belt driven and built on a fabricated base to minimise noise and vibration. Machine feet eliminate vibration transfer to and from the floor. This design gives the operator a shorter reach to the plate and easy access underneath for maintenance. The main lap plate can rotate both directions, and the work holder will automatically oscillate.

The machine will operate with a free abrasive compound such as silicon carbide, alumina or boron carbide, suspended in a oil or water based vehicle or a Diamond Compound. The compound is fed onto the lap plate from a free-standing system via a peristaltic pump.

As with all lapping machines of the Dual Face lapping type, we recommend that the lap plates are re-conditioned using conditioning gears on a regular basis. The machine can also be fitted with diamond dispensing equipment and special complementary lap plates.

The machines come fully equipped and ready to run. The controls are housed in a single steel console attached to the base frame at a convenient working height. In all cases the lapping operation is controlled by a multi range adjustable timer or optional DTI mode.

Features & Benefits:

- Heavy duty fabricated steel body
- Gear reducer, 125 rpm max plate speed
- 2 Adjustable motor drives
- Outer gear speed 0 - 111 rpm 60W DC drive
- Inner gear speed 0 - 125 rpm 60W DC drive
- Electronic digital timer, 0.1 second to 999 hours
- 0.3 Litre compound distribution system with Peristaltic pump & Stirrer
- 2 Individually adjustable feed arms
- Operator controls at 24VDC
- Interlocked guarding
- Abrasive slurry distribution system with reservoir tank
- CE compliant
- Stainless steel 304 wetted parts
- Waste tank

Options:

- TwinLap 50 for components <50 mm dia x 10mm thick
- TwinLap 120 for components <120 mm dia x 10mm thick

Kemtech III Geological Lapping Machine

The Kemtech III Geological lapping machine is able to accurately lap and polish thin sections mounted on glass slides down to 30 microns. Metered dosing of conventional and/or diamond abrasives is applied to the lapping plate using the aKu-Disp Geo peristaltic dispenser. The Kemet Lift Off Disc system allows quick transitions between the lapping and polishing stages.



Features & Benefits:

- Integrated abrasive tank with stirrer
- Sealed maintenance free reduction gearbox
- Cast iron Serrated Lift Off Disc or Aluminium Lift Off Disc
- Variable Speed up to 70 rpm
- Water Trap and Filter
- Stand-alone vacuum pump
- aKu-Disp Geo accurate peristaltic dispensing system for metered dosing
- Capacity for up to 3 vacuum jigs with diamond faced stoppers
- Electronic digital timer with variable time ranges

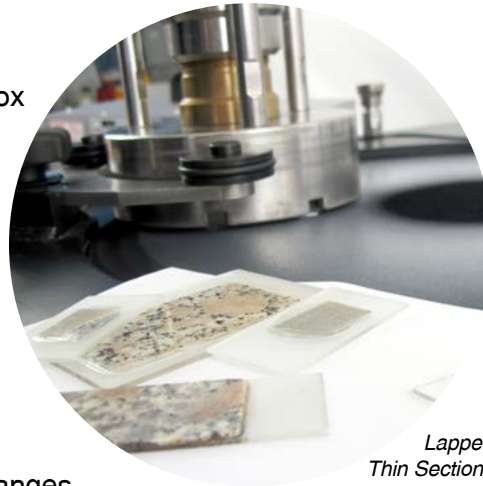

Technical Specifications

Height	400 mm
Working Height	310 mm
Width	800 mm
Depth	650 mm
Nett Weight	90Kgs
No of jig stations	3
Main Motor	0.37kW
Product code	359975

Also available in 20" with driven rings as an option.

Vacuum Jigs (to suit slides)	Code
4 x (76 x 26 mm) or 2 x (76 x 51 mm)	362072A
6 x (52 x 26 mm)	362072B
1 x (100 x 100 mm)	362072C
6 x (48 x 28 mm)	362072D
3 x (45 x 60 mm)	362072E
Rotaid rotation assist post	362895
Setting stand	361986
Cast iron setting test block (127 mm diameter)	361773



The Kemet Vacuum Jig is a precision workholding and sizing fixture. The Jig is suitable for accurately sizing Geological thin sections, wafers, crystals and any precision parts where parallelism and precision finish are required.

Recommended Accessories	Code
Set of 3 Cast Iron Serrated Conditioning Rings	360203
Set of 3 Plastic Faced Conditioning Rings	361521
380 mm Cast Iron Serrated Lift Off Plate	362433
380 mm Aluminium Lift Off Disc	361001
380 mm Aluminium Drive Plate	361002
380 mm Thin Metal Disc (For use with magnetic system)	345563
380 mm Magnetic Disc	345773

Recommended Consumables	Code	
Diamond Suspension (Water based mono diamond)	9 Micron AQUAPOL-M	219442
	6 Micron AQUAPOL-M	219448
	3 Micron AQUAPOL-M	219440
	1 Micron AQUAPOL-M	219450
Green Silicon Carbide Powder F600 1Kg	361513	
380 mm PSU-M Chemo-Textile Cloth	341011	
380 mm MRE Short Napped Final Polishing Pad	341715	

aKu-Disp	Code
aKu-Disp unit	362820
Integration kit for Kemtech III 110V	362823
Integration kit for Kemtech III 230V	362822

Kemet 300L Models

The Kemet 300L machines are fitted with a serrated cast iron or Kemet Composite Lift-Off Disc to suit the application. A single control ring is located in a ring style holder and runs between 3 rollers. This is adjustable for both height and position.

Recommended Accessories

Hand weight	345450
Serrated Cast Iron Conditioning Ring	345434

Technical Specifications	
Lapping Plate outside Diameter	300 mm
Lapping Plate Speed	0 - 130 rpm
Conditioning Ring inside Diameter	125 mm
Conditioning Ring Outside Diameter	140 mm
Standard Electrical Supply	220V-single phase-50Hz or 110V-single phase-60Hz
Main Drive Motor	High Torque Motor (1 HP) 0.75kW
Dimensions (mm)	420 x 730 x 350
Weight	37kg
Product code	345459



Kemet 300 LVAC Polishing Machine

The Kemet 300 LVAC special purpose polishing machine is a smaller alternative to the Kemtech 15 geological lapping machine for polishing geological mounted samples.

Technical Specifications	
Lapping Plate outside Diameter	300 mm
Lapping Plate Speed	0 - 130 rpm
Conditioning Ring inside Diameter	125 mm
Conditioning Ring Outside Diameter	140 mm
Standard Electrical Supply	220V-single phase-50Hz or 110V-single phase-60Hz
Main Drive Motor	High Torque Motor (1 HP) 0.75kW
Dimensions (mm)	420 x 730 x 350
Weight	37kg
Product code	345467



The machine has a 300mm diameter plate with drive elements mounted on a heavy duty aluminium alloy casting, giving vibration free operation and silent running. A water inlet with a control valve are standard features while the control panel has a process timer, variable speed control and forward / reverse control switch. The machine has it's own vacuum pump and connectors to suit Kemet vacuum jigs, which are available as an optional extra (see page 11).

Special Purpose & Bespoke Machines

As well as these standard flat, spherical, match and internal lapping machines, Kemet also offer a bespoke machine manufacturing service for applications where an off the shelf system is not available. This can be as basic as converting a hand finishing operation to an automated process, or as complex as a conveyor fed single piece lapping system capable of producing a finished part every 9 seconds. No application is too small for consideration.



Lapping Consumables

Kemet Composite Lapping Plates

Manufactured from a homogeneous mixture of synthetic resins and metal particles, the plates are designed for Kemet's advanced lapping technology, perfectly compatible with Kemet's extensive range of Liquid Diamonds.

Benefits

- Holds diamond particles firmly, ensuring both efficient stock removal and repetitive component surface finish.
- Ductile qualities cushion the diamond particles, preventing damage to the workpiece.
- Produced in varying hardness values so that even the softest material can be safely lapped with diamond particles without the fear of impregnation.
- Easy control for optimum flatness.
- Lapping/polishing plates available to fit all makes of lapping machines with plate diameters up to 3000mm.
- Recommended when high precision flatness and surface finish are required.
- Dissipates heat and prevents laminar flow of lapped surfaces.
- Supplied with a cast iron backing plate for maximum stability.

Composite Material	Plate Diameter (inches)			
	15	20	24	36
Kemet Copper	351102	351103	351106	351124
Kemet Copper SP2	351159	351964	351177	351965
Kemet Iron	351002	351081	351006	351010
Kemet PR3	351340	351374	351357	351343
Kemet Tin	351305	351320	351306	351315
Kemet XL	351356	351375	351376	351377
Kemet XP	351202	351266	351206	351227

Custom sizes and grooving are available.

Composite Material	Description
Kemet Iron	The most commonly used plate. For general purpose stock removal and lapping operations.
Kemet Copper	Used to lap softer materials where fine lapping and polishing are the primary requirements.
Kemet Copper SP2	Can be used for lapping and/or polishing hard and medium hardness materials.
Kemet PR3	Used to generate highly reflective surface finish. Ideal for pre-pad polishing for minimum roll off.
Kemet XL	Replacement for Lead/Tin plate, used for mirror polishing.
Kemet XP	Gives improved flat polished surfaces on many materials. Flat mirror-like surfaces can be produced on many hard materials.
Kemet Tin	One of the softest Kemet Plates used for mirror polishing with fine grades of Kemet Liquid Diamond.

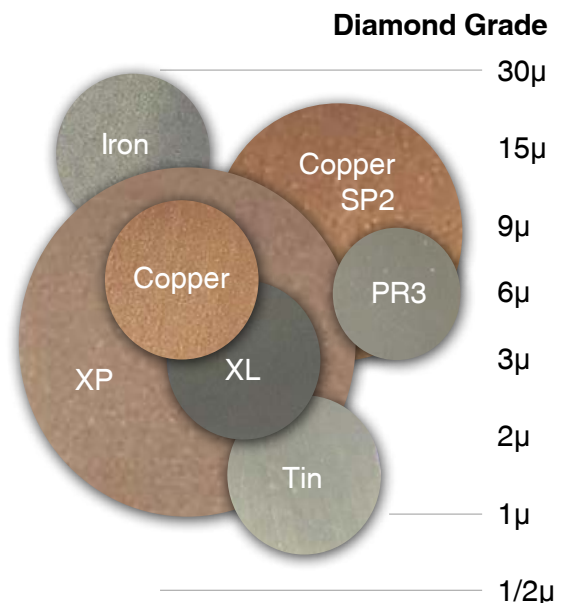

Lapping Plate Grooving

Lapping plates can be supplied grooved to suit specific applications. A cross hatched pattern is common on Cast Iron Hand Lapping plates and Dual Face Machine plates and gives increased stock removal rates due to increased surface pressure and the additional cutting edges generated on each groove. A Spiral groove pattern is used primarily when polishing parts that need to have a good surface finish and flatness, allowing contamination to be carried away from the cutting surface and making it easier to keep the lapping plate contact surface flat. The edges of the groove maintain good stock removal even through the diamond particle size may be small.

Annular Grooved Plates

These plates are designed for precision shoulder lapping of a wide range of parts, such as fuel pump gear faces and pressure relief valve caps. These are bespoke manufactured and the groove width and depth of plates need to be specified when ordering.



Lift Off Disc System

Suitable for multistage processing when workshop space is a premium or budget constraints only allow a single machine. Kemet Lapping Plates are available as Lift-Off Discs 300mm or 15" diameter. Discs are supplied mounted on an aluminium backing plate, which locates onto an aluminium drive plate by means of three pegs. Lift Off Discs can be easily changed and are recommended for light duty work where general flatness and precision finish are required.

Description	300mm	15"
Aluminium Drive Plate	-	361002
Aluminium Lift Off Disc	345114	361001
Kemet Iron Lift Off Disc	351303	351025
Kemet Copper Lift Off Disc	345117	351121
Kemet Copper SP2 Lift Off Disc	351381	362276
Kemet XP Lift Off Disc	351219	351226
Kemet Tin Lift Off Disc	-	351314

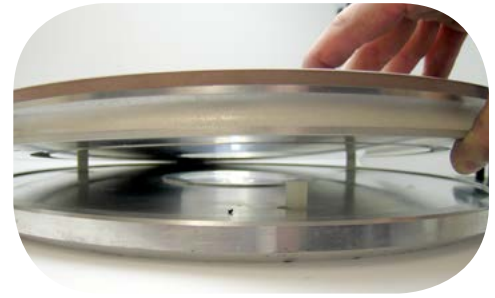

Kemet Composite Lapping Rods

For use with Kemet's diamond compounds, Kemet composite rods are manufactured from a homogeneous mix of synthetic resins, metal particles and other materials. Produced in a variety of hardness values, the softest materials can be safely lapped with Kemet Diamond compound. They are commonly used to improve the surface quality of parts following lapping with Kemet Helilaps.

Type	Diameter Size (mm)		
	25x150	50x150	75x150
Kemet Iron	352101	352102	352103
Kemet Copper	352104	352105	352106
Kemet XP	352113	352108	352114
Kemet Tin	352107	352116	352163



Conditioning Rings

Cast Iron Conditioning Rings available as solid or serrated. Replacements are available to fit most flat lapping machine models. Plastic faced and ceramic faced conditioning rings are also available and these are used for polishing rather than lapping operations.

Lapping Machine	Solid (ci)		Serrated (ci)	
	3 Ring	4 Ring	3 Ring	4 Ring
Kemet 15	360204	-	360203	-
Kemet 20	360818	-	361027	-
Kemet 24	360679	360680	360208	360274
Kemet 36	360186	360681	360278	360682
Kemet 40	*	*	360683	*
Kemet 48	360662	360235	360833	360642

* Available on request

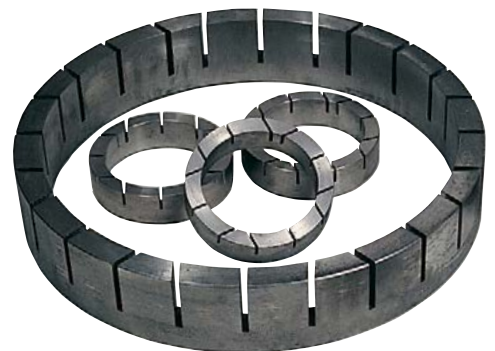

Diamond Dressing Ring

For rapid correction of Kemet Lapping Plates. Supplied with diamond pellets glued to the cast iron conditioning ring. A 36" diamond dressing ring can correct a +25µm convex plate in 17 minutes. A Kemet 15" diamond dressing ring can correct a +15µm convex plate in 2 minutes. Other sizes available upon request.

Lapping Machine	Dressing Ring
Kemet 15	362677
Kemet 24	362678
Kemet 36	362668



Kemet offer a refacing service when the Kemet Composite material falls below 3mm thickness.



Dressing Pads

Kemet Diamond Dressing Pads come in two different varieties - coarse and fine. They are self adhesive and are fixed to the bottom of cast iron conditioning ring for rapid plate flatness correction on Kemet Lapping Machines.

Grade	Unit	Code
Fine	Pack of 8	361524
Coarse	Pack of 8	361525
Fine	Pack of 12	361526
Coarse	Pack of 12	361527



Cast Iron Lapping Plates / Segments

Kemet offer a wide range of cast iron lapping plates and segments to suit most lapping machines.

Cast Iron Lapping Plates (Pre-lapped)	Plate Diameter (inches)			
	15	20	24	36
Serrated	362400	362402	362404	362406
Solid	362401	362403	362405	362407

* Other sizes available on request



Cast Iron Hand Lapping Plates

The Cast Iron plates are made from high quality, low porosity grey cast iron (Grade 300 to BS1452). These are used with an abrasive grit, applied in paste form to give a uniform dull matt finish on a wide variety of metallic and non-metallic materials. Other sizes available.

Description	Disc Diameter						Square (WxLxH)
	3"	4"	6"	8"	12"	18"	12" x 12" x 2"
Hand Lap Plate c/hatch grooves	-	-	361021	360835	360198	360707	362473
Hand Lap Plate solid	361797	361736	361738	361739	360264	360762	-



Soft Metal Hand Lapping Plates

The Soft Metal plates are made of Tin.

Description	6"	12"
Hand Lap Plate SOFT METAL	361049	361046

Liquid Diamond

Our range of Kemet Liquid Diamond products are available as oil soluble, water soluble or as emulsions. The chemical composition of the carrier fluids is carefully controlled to ensure that they are compatible both with the Kemet Lapping Plate and the components being lapped.

- Precision graded diamond particles in a fluid.
- Optimum viscosity and chemical composition of each Liquid Diamond Product gives fast stock removal with the ability to produce superfine surface finishes.
- Suitable for dispensing with the Kemet Electronic Dispensing System and aKu-Disp thus eliminating wastage and reducing lapping costs.
- Specially formulated Liquid Diamond Products enable parts to be easily cleaned.



Liquid Diamond

TYPE K (Oil / water emulsion) TYPE O (Oil based)

An excellent, low viscosity oil/water emulsion suitable for all general purpose lapping.

An excellent, general purpose, low viscosity oil based suspension suitable for heavy parts and high volumes.

Micron	TYPE K						TYPE O						
	400g			2000g			400g			2000g			
	Standard	Strong	Extra Strong	Standard	Strong	Extra Strong	Standard	Strong	Extra Strong	Standard	Strong	Extra Strong	
A	1	211004	211024	-	211084	211105	-	216004	216024	-	216085	216104	-
	2	211005	211025	-	-	-	-	216005	216025	216045	216081	216105	216136
	3	211006	211026	211046	211086	211106	211126	216006	216026	216046	216086	216106	216137
	4.5	211007	211027	211047	211087	211107	211127	216007	216027	216047	216087	216108	216138
B	6	211008	211028	211054	211088	211108	211128	216008	216028	216048	216088	216107	216139
	8	211009	211029	-	211089	211109	211129	216009	216029	216049	216089	216109	216140
	10	211010	211030	211050	211132	211110	211130	216016	216030	216050	216095	216110	216141
	14	211011	211031	211051	211091	211111	211131	216011	216031	216051	216092	216111	216142
C	25	211012	211032	211052	211092	211112	211133	216012	216032	216052	216090	216112	216143
	45	211013	211033	211053	-	-	-	216013	216033	216053	216094	216113	216144

A = Final Polishing B = Lapping & Pre-polishing C = Rapid Stock Removal

* Sub micron grades available on request

FastCut (Water based) Liquid Diamond

FastCut offers a water based solution that, in tests, exceed the performance of oil based products by as much as 25%.

- The latest generation of water soluble liquid diamond
- Excellent stock removal
- Easy to clean
- Non-foaming
- Zero VOCs (volatile organic compounds)
- Available from 1 Micron to 25 Micron in 400g or 2000g
- Lubricating Fluid Type W9 recommended with FastCut Liquid Diamond

Micron	Product Code	
	400g	2000g
1	219416	219417
3	219418	219419
6	219420	219421
8	219422	219423
14	219424	219425
25	219426	219427



DiaCarb - For Polishing Carbon and Carbide Seals

Dia-Carb offers just the right amount of “wetting” of the cast iron plate, enabling the required “polish” to be achieved on Carbon, Tungsten Carbide and Silicon Carbide seal faces in much shorter process times - perfectly polished mechanical seal faces every time. If you need advice on polishing carbon or carbide mechanical seal faces, or if you would like your current process assessed completely free of charge with no obligation, contact Kemet International.

DiaCarb Product Code	
400g	2000g
219200	219201

Kemet offer a wide range of standard and special Diamond Products formulated and manufactured in our quality controlled laboratories. Request our ‘Diamond catalogue’ for our full range.

* ZERO Volatile Organic Compounds (VOC) - not classified as an atmospheric pollutant and offer health and safety benefits. VOCs are organic chemicals that have a high vapour pressure at ordinary room temperature, some of which can be dangerous to human health and/or cause harm to the environment.



Diamond Compound / Paste

For hand lapping applications Kemet offer a huge range of Diamond Compounds for rapid stock removal, superfine surface finish, lapping and pre-polishing. Micron sizes ranging from 1/10 to 90, soluble in either oil (Type L), water (Type W) or both (Type KD). High thermal stability of the chemical carrier ensures that Kemet Diamond Compound resists frictional heat, remains stable, and keeps its suspension properties under operating conditions.

For our full range of Diamond Compounds, please view our [website](#) or diamond catalogue (available on request).

Lubricating Fluids



- Assists Kemet Diamond Products to cut and polish more effectively by absorbing frictional heat and diluting the lapping residue.
- Lubricant performance remains stable even when under high pressure.
- Manufactured from high purity chemicals.

Type	Description	Soluble in	Colour	450ml Trigger spray	2.5 Litres	25 Litres
W	Recommended for use on all Kemet Polishing Cloths as it helps to extend their life	Water	Clear	301201	301101	301151
W9	Recommended for use with FastCut Liquid Diamond	Water	Clear	*	301527	*
W2	Developed for use with Kemet Diamond Suspension, particularly when used with Kemet Lapping Plates. (GW2 is odourless)	Water	Clear	301202	301102	301205
GW2		Water	Light green	301514	301108	*
BLUE	Improves cutting and polishing performance on cloths or plates	Water	Blue	301200	301156	*
LS	Where components need to undergo a water based cleaning operation after lapping	Oil/Water	Blue	301204	301104	*
K	Assists smooth running of the lapping operation and helps to ensure a cleaner process	Oil	Clear	301178	301124	301125
R OS2	For use where water is not permitted	Oil	Red	301513	301512	*
OS	Recommended when polishing tooling, moulds and similar components	Oil	Blue	301203	301103	301112

* Available on request



Universal Lapping Oil

Lubrication is necessary for a smooth running condition between the lap plate and conditioning rings and to help evenly disperse the abrasive product on the lap plate. Lapping vehicle used with any abrasive powder should be properly matched in order to give the best cutting action possible, maintain even dispersion of abrasive throughout the lapping surface, and produce uniform finishes. The proper lapping vehicle in conjunction with the right abrasive will reduce lapping time and reduce the amount of slurry needed to complete the job. A typical mix would be 1kg of abrasive to 5 Litres of lapping oil.

Size	Code
5 Litres	361516
20 Litres	361517
205 Litres	361498

Kemox - Abrasive Slurry

Kemox is a conventional lapping abrasive that has been suspension treated so that the abrasive particles do not settle out into a hard sediment in the bottom of the abrasive tank. Kemox is available in water soluble (Kemox-W) or oil soluble (Kemox-O) formulations in 5 or 20 Litres. The abrasive concentration is always correct and eliminates the health and safety risk of adding powder to oil.



Product	5 Litres	Micron Size	Description
Kemox O-960	300101	3	Oil Based. Finest surface finish on soft components
Kemox O-950	300102	6	Oil Based. Finer surface finish on soft components
Kemox O-900	300103	9	
Kemox O-800	300104	13	
Kemox O-800S	300112	14	Oil Based. General aluminium oxide lapping where a scratch free matt lap is required
Kemox O-800 (Fine)	300107	14	
Kemox O-800 FHC	300109	14	
Kemox O-400	300105	22	Oil Based. Plate conditioning and matt lapping where good stock removal and a matt lap is required
Kemox O-400S	300111	22	
Kemox W-950	300152	6	Water based where oil can't be used. Finer surface finish on soft components
Kemox W-800	300143	13	Water based
Kemox W-400	300141	22	

Kemox SF - Aluminium Oxide Treated Suspension

Benefits

- Extremely strict selection process for particle size, shape and hardness to ensure maximum polishing performance over an extended life cycle
- Superior surface finish
- Excellent stock removal rate
- Easy clean up
- Long life
- Low viscosity to promote improved flow for polishing materials

Size	Code
5 Litre	300199
3.8 litres	300200
1 Litres	300207



Before and after using Kemox SF on Aluminium

Col-K - Colloidal Silica Suspension

A Liquid polish used on Kemet Chem Cloth to produce the ultimate in high quality mirror polishes on polishing machines. A part abrasive, part chemical polishing action makes Col-K well suited to polishing difficult materials such as Stellite and Cobalt Chrome. Also available in non crystallising version called Kemet Col-K (NC).

Size	Col-K	Col-K (NC)
1 Litre	600262	600261
5 Litres	600212	600199
20 Litres	600204	600202





Lapping Pastes & Powders

Kemet manufacture a wide range of abrasive lapping pastes. Our range of Silicon Carbide and Aluminium Oxide pastes have many applications but are particularly suited to the lapping of mechanical seals and valve seats. The pastes are **water soluble** and safe to use.

Product	Type	Micron	FEPA Grade	Powders		Product	Type	Micron	FEPA Grade	Pastes 1kg
				5 kg	25kg					
Green Silicon Carbide	Fine	3	1200	361537	361616	Silicon Carbide	Fine	3	1200	361547
		5	1000	361535	361536			5	1000	361552
	Medium	9	600	361563	361631		Medium	7	800	362616
		17	400	361512	361579			9	600	361514
		37	280	361532	361629			17	400	361551
		75	180	361541	361653			23	360	361548
Black Silicon Carbide	Medium	9	600	361562	361651		Coarse	30	320	361558
		22.8	360	361648	361649			37	280	361538
	37	280	361646	361647	75			180	361549	
	53	230	361644	361645	109			120	361689	
Aluminium Oxide	Medium	7	800	361676	361615	Aluminium Oxide	Fine	3	1200	361544
		9	600	361555	361614			5	1000	361624
	Coarse	23	360	361554	361561		7	800	361545	
Coarse	9	600	361555	361614	9		600	361543		
	13	500	361546							
	23	360	361542							

Sabre Aluminium Oxide Paste

Specially formulated containing Aluminium Oxide Abrasive and is available in 20g syringes. It is suitable for a wide range of lapping/polishing operations, and it is particularly effective when used for smoothing soft metals such as brass, aluminium and copper. It is also effective for smoothing small areas of glass prior to polishing. Sabre Pastes are also available based on both silicon carbide and boron carbide abrasives.

Micron	Code
0.1	300206
0.5	300205
3	300204
7	300203
9	300202
23	300201



Aluminium Oxide Lapping Film

Tightly graded aluminium oxide coated onto a 0.3mm thickness polyester film backing. Available with or without PSA (pressure sensitive adhesive).

- Excellent surface finish
- Reduces overall process time
- Produces high yields
- Non-slurry processing

216 x 280 mm sheet plain backed Aluminium Oxide Lapping Film - Supplied in packs of 50

Micron	Colour	Code
0.3	White	361706
1	Green	361707
3	Pink	361708
5	Brown	362420
6	Blue	361709
12	Yellow	361710
30	Green	361711
40	Blue	361712
60	White	361713



Diamond Lapping Film

Kemet precision coated diamond abrasive lapping film products are specifically engineered to meet all your ultra-fine, consistent polishing and final finishing requirements.

- Wide range of engineered, tightly-graded micron-sized particles. Ensures consistent, long-lasting polishing. Generates scratch free surfaces; achieving Ra values under 1 micro-inch on hard materials, including HVOF depositions. Improves coolant access at point of contact
- Proprietary resin system improves adhesion to substrate
- Uniform 3 mil polyester film backing, ensures film flatness and improved part geometry
- Compatible with most machinery attachments and all coolants, allowing quick film replacement
- Long life and offers high yields, reduced rework, and uses fewer steps for lowest total abrasive costs

Microns	Roll Width	Roll Length	Disc Diameter	Sheet Size
1, 3, 9	>= 12"	50' - 150'	>= 12"	>= 12" x 12"
9, 15, 30, 45, 60, 76, 100	>= 12"	50' - 150'	>= 12"	>= 12" x 12"
1, 3, 6	>= 12"	50' - 150'	>= 12"	>= 12" x 12"

Standard roll <= widths 50, 100 and 200 mm. Other <= widths are available on request.

Micron	230 x 280 mm	300mm Ø (PSA)
0.5	362901	362997
1	362549	362998
3	362550	363004
6	362902	363002
9	362903	363001
15	362040	363000
30	362904	362999

Kemet Diamond Lapping Film, Plain Backed



Diaflex - Diamond Grinding

Kemet Diaflex is a self adhesive, flexible diamond material which combines the long life and aggressive cutting action of diamond with the flexibility of cloth. It is supplied in either discs or squares, and a wide range of grit sizes. The diamond is either nickel bonded (N) or resin bonded (R). It is suitable as a grinding step in either metallographic sample preparation or flat lapping. Diaflex can be supplied as plain backed.

Grade	Grit / Micron Size	Disc (mm)					Square (mm)		
		150	200	230	250	300	100 x 100	150 x 150	300 x 300
Green (N)	60 / 250	342074	342025	342075	342076	342068	342011	342013	342048
Black (N)	120 / 125	342001	342002	342077	342026	342027	342014	342070	342049
Red (N)	200 / 74	342004	342005	342067	342028	342029	342016	342036	342050
Yellow (N)	400 / 40-50	342006	342007	342071	342030	342031	342018	342066	342051
White (N)	800 / 20-30	342032	342008	342072	342033	342034	342020	342037	342052
Yellow / White (R)	800 / 20-30	342078	342035	342079	342080	342047	342038	342044	342053
Blue (R)	1800 / 6-12	342042	342009	342073	342081	342084	342043	342021	342054
Orange (R)	12000 / 1-3	342069	342010	342082	342083	342085	342022	342023	342055







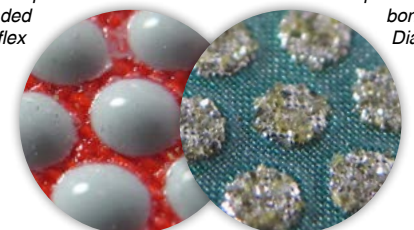

Close-up of resin bonded Diaflex

Close-up of nickel bonded Diaflex



Kemet Polishing Pads

Flat polished surfaces on many softer materials can only be produced with polishing pads. Available to suit most grinder/polisher and flat lapping machines, Kemet offer the widest range of self-adhesive and metallic backed polishing pads. These are generally split into three types: Chemo-textile, Nap and Synthetic Silk

Name	Type	Description	Use with Recommended Diamond Micron size	Ø 300mm	Ø 15"/ 380mm	Ø 24"/ 610mm	Ø 36"/ 914mm	Colour
PSU-M	Chemo-textile These are manufactured to the highest standards with accurately controlled uniform thickness. Self-adhesive. Non-woven pads manufactured specially for polishing processes.	These medium and hard chemo-textile cloths are for smoothing and polishing operations.	15 micron and finer	341010	341011	341012	341035	
PSU-MM (magnetic)				341813	341814	341837	341838	
NSH-B	Nap Cloths For final polishing stages of preparation, Kemet Nap Type Cloths are available with a range of softness and nap length. They give a more gentle polish, and are ideal for softer specimens and components. All cloths are self-adhesive unless marked 'plain'.	A short nap cloth with woven backing used for metallographic and some optical polishing operations.	3 micron and finer	341203	341243	-	341259	
NSH-BM (magnetic)				341262	341264	341265	341266	
NLH		A longer, stiffer nap cloth.	6 micron and finer	341206	341248	-	-	
NLH-M (magnetic)				341267	341296	-	-	
CHEM-H		For use with a chemical mechanical polishing process with colloidal silica suspension.		341784	341865	341786	341866	
Chem-HM (magnetic)				341853	341854	341856	341855	
MRE		Synthetic flock on a flexible waterproof carrier. A more heavy duty cloth	6 micron and finer	341714	341715	341877	341942	
MRE-M (magnetic)				341817	341818	341819	341828	
ASFL	Synthetic Silk Durable woven structure, developed for finishing metal specimens and components.	Synthetic silk pad with durable woven structure for mirror finishing of most metals.	6 micron and finer	341111	341112	341113	341140	
ASFL-M (magnetic)				341177	341178	341179	-	
MSFL		Will polish metal flat, and to a mirror finish.	3 micron and finer	341755	341756	341757	341759	

Supplied in packs of 10. Other sizes available on request.

Type	Description	Square (mm)
		127 x 127
Spherichloth A	For general purpose, single use spherical polishing pads.	341998
Spherichloth B		341966
NLH	For high gloss spherical polishing	341276

Supplied in packs of 10



Magnetic Polishing Pad Systems

The Kemet magnetic disc system is suitable for Kemet's range of magnetic polishing pads (marked 'magnetic' above), diamond grinding and fine grinding discs, and any magnetic consumable from other suppliers.

- Easy to change and cloths last longer
- No adhesive breakdown problems
- Faster and cleaner cloth changes
- No metal disc involved so safe to use

Magnetic Disc Size	Code
Ø 300 mm	345772
Ø 380 mm / 15"	345773
Ø 610 mm / 24"	345774
Ø 914 mm / 36"	345775

Workholding and Holders

Workholding is one of the most important factors when carrying out a lapping operation. The flatness of a part can be adversely affected by incorrect workholding.

Non skid pads for all machines can be supplied, together with blank workholding discs. This is placed directly on top of the parts which have been positioned inside the conditioning ring.

Lapping Machine	Diameter	Thickness	Code
Kemet 15	138mm	3mm	360206
Kemet 15	138mm	6mm	360678
Kemet 20	189mm	3mm	362460
Kemet 24 (3 ring)	246mm	3mm	360269
Kemet 24 (3 ring)	246mm	6mm	360232
Kemet 36 (3 ring)	366mm	3mm	360280
Kemet 36 (3 ring)	366mm	6mm	360285
Kemet 48 (3 ring)	503mm	6mm	360248
Kemet 56 (3 ring)	576mm	6mm	362498



Kemet Facing kit

The Kemet facing kit consists of a non-skid rubber pad. This pad can be fixed to the bottom surface of the hand weight. The hand weight with the pad is then placed directly on top of the parts which have been positioned inside the conditioning ring. Lapping can occur and the parts will not skid out of position.

Lapping Machine	Code
Kemet 300L	362458
Kemet 15	361503
Kemet 20	361972
Kemet 24	361504
Kemet 36	361509



Dycem

This non-slip material has a protective film on both sides, which will keep the material clean until ready to use.

Dimensions: 406 mm x 9 m

Product	Code
Dycem	361505



Foam Tape

Double sided self-adhesive foam tape.

Dimensions: 3 mm thick, 50 mm wide and 25 m long.

Product	Code
Foam Tape	361506



Polishing Stand with Paper

Recommended for polishing workpieces to produce reflection needed for viewing under monochromatic light sources.

The heavy-duty polishing table is provided with a tensioning mechanism for smooth pulling of the polishing paper. Table dimensions 350 x 280 mm.

Product	Code
Polishing Stand	361560
Hand Polishing Paper (Grit 2000) 50 m x 305 mm	362162



Lapping Accessories

Electronic Dispenser System



The Kemet Electronic Dispenser distributes Liquid Diamond and Lubricating Fluid by means of touch sensitive settings. The digital display shows dispensing intervals, durations and air pressure at a glance. The dispenser achieves great accuracy, eliminating wastage and simplifying cost control.

The Kemet Liquid Diamond Stirrer Unit maintains a consistent distribution of diamond particles within the slurry by using a small non-contaminant plastic coated paddle magnet, which ensures even diamond suspension. The Kemet Dual Dispensing Bar can be positioned to dispense Liquid Diamond and Lubricating Fluid accurately on to the plate without spray bounce.

- Supplied as standard with Kemet Flat Lapping and Polishing Machines and Plates
- Easily fitted to existing conventional Flat Lapping Machines to improve productivity
- Fully controlled metering of Liquid Diamond and Lubricating Fluid using independent pressure and time settings
- Electrical system complies with EN 60 204.
- Can also be used as a standalone unit for bespoke applications that require controlled dispensing
- Dispenser Service Kit available to keep the unit in optimal use - Product Code: 362530



Electronic Dispenser				
Height	Width	Depth (exc. air filter)	Nett Weight	Code
150 mm	230 mm	150 mm	3.74kg	360499

Dispenses Kemet Liquid Diamond and Lubricating Fluid automatically at pre-set intervals in conjunction with a lapping and polishing machine cycle timer.

Air requirements: 1 Bar min - 5 Bar max. **Air pressure:** Dual circuit. **Air pressure display:** Bar or psi
Adjustable duration of spray: 1-9 seconds. **Adjustable intervals of spray:** 1-999 seconds
Spray memory: Standard. **Manual override:** Standard
Electrical supply: 110V or 220V - 240V / 50Hz or 60Hz (self adjusting for supply voltage & frequency)



Liquid Diamond Stirrer Unit				
Height	Width	Depth	Power	Code
120 mm	90 mm	215 mm	50Hz or 230V	360534
			60Hz 110V	360536

Quiet electric unit has fully variable speed control and is provided with a magnetic stirrer paddle also holds the bottle for the lubricating fluid.



Single Spray Head	
Length	Code
250 mm	360514
380 mm	360512

Supplied with bottle, cap and plastic tubing.



Dual Dispensing Bar & Bottles						
Type	Length	Reach	Adjustable Height	Section of head	Bottle capacity	Code
Standard	340 mm	260 mm	100 mm	20 x 20 mm	400ml	360511
Long	495 mm	415 mm	100 mm	20 x 20 mm	400ml	360510

Supplied complete with two bottles and plastic tubing. Fully adjustable head for vertical and radial positioning.

aKu-Disp Peristaltic Dispenser

The Kemet aKu-Disp is designed to work in conjunction with Kemet Lapping Machines. The aKu-Disp operates whilst the machine is running to provide accurate metered dosing of abrasive slurry to the lapping/polishing application. The unit's stirrer function begins to operate as soon as power is switched on and variable speed controls for both the pump and stirrer can be adjusted.

Features

- Variable speed stirrer and pump controls
- Constant movement of fluid in tubes when on standby to avoid hardening of abrasive
- Can operate as a stand-alone unit
- Auxiliary contact relay for timer integrated control
- Priming function to charge pipe and spray head prior to use
- Voltage: 230V-1phase-50Hz
- Variety of integration kits available

Product	Code
aKu-Disp unit	362820



Lapping Machine Maintenance Kit

This Kit is used for the general maintenance of the Kemet 36 (and larger) Diamond Lapping machines.

The Kit comprises of: 1 Grease gun, 1 Oil gun, 1 Litre of gearbox oil and 1 EP2 grease cartridge

Product	Code
Lapping Machine Maintenance Kit	362220



Flatness Gauges

The Kemet 9" Flatness Gauge is used to monitor a lapping plate's flatness and to give an indication of the flatness the plate will produce on a given part size. The gauge comes with a calibrated single-sided master setting block and is supplied with instructions.

- Span of Gauge: 9.29" (236mm)
- 1 Micron Accuracy
- Recalibration service available
- Suitable for lapping plates 15" to 36" diameter

Product	Code
9" Flatness Gauge	361304



Colour Coded Flatness Gauge

Colour Coded Flatness Gauge Kit (Available for 24" & 36" Lapping Plates) for easier use of the Flatness Gauge.

Product	Code
Colour Coded Flatness Gauge Kit <i>(Different kits available depending on machine & setup)</i>	Contact Kemet



Straight Edges to Measure Plate Flatness

Steel straight edges to measure plate flatness. Manufactured to DIN 874.

Description	For Lapping Machine Model				
	15	20	24	36	48
Length	500mm	500mm	750mm	1000mm	1500mm
Cross section	40mm x 8mm	40mm x 8mm	50mm x 10mm	50mm x 10mm	60mm x 12mm
Code	361501	360864	361502	360239	360861





Monochromatic Light Source

Produces clear flatness readings when used with Kemet Optical Flats. The compact designed light is easily transportable and uses a sodium long-life light source. Supplied with a flatness reading interpretation chart.

- Detachable power lead with on / off switch at the side
- Supplied with compliance certificate and instructions
- CE marked

Description	Code
Monochromatic Light - 230v	361201
Monochromatic Light - 110v	361211
18W Sodium lamp (for old model)	361204
35W Sodium lamp	362607



Optical Flats

Produced from Quartz, Kemet Optical Flats are available in single and double sided, 1/4 and 1/10* light band accuracy, in sizes from 25mm up to 400mm diameter**. They are supplied with Certificate of Conformity with full traceability to international standards. Special optical flats are available on request. Kemet offers an optical flat reconditioning and calibration service.

Size	Single Sided		Double Sided	
	1/4	1/10	1/4	1/10
25mm	361220	361221	361237	361238
50mm	361222	361223	361215	361239
75mm	361224	361225	361705	361240
100mm	361226	361227	361210	361241
125mm	361228	361229	361242	361214
150mm	361123	361231	361216	361243
200mm	361232	361233	361219	361244
250mm	361234	361235	361217	361245
300mm	361218	361236	361246	361247

* Higher accuracy available on request.

** Larger sizes made to order with configurations such as squares, rectangles and donut shapes and custom thickness are available.

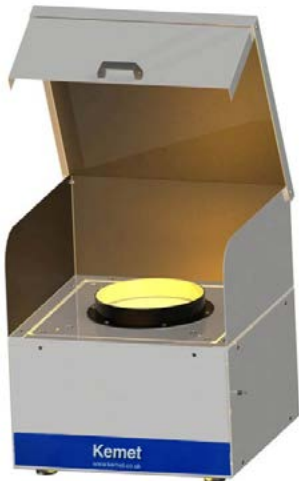

Optical Flat Stands

Large optical flats (250mm diameter and above) are heavy. If they are placed directly onto a thin component such as mechanical seals, they can cause distortion of the component and incorrect light band readings. Kemet Optical Flat Stands allow the part to be placed onto the optical flat surface meaning there is no distortion. They also allow a single large optical flat to be used on a wide range of part sizes.



Optical Flat Cleaning and Care Kit

This Kit is used for cleaning Kemet Optical Flats. Taking special care of these will ensure accuracy and long service.

The Kit comprises of:

- 1 Soft Optical Lens Brush
 - 1 Kemet Lens Klean Fluid 250ml
 - 1 pack of Kemet Sphericloths (Containing 25)
 - 1 pack of Kemet Moist Lens Wipes (Containing 20)
 - 1 pack of Kemet Dry Lens Wipes (Containing 20)
- Full Instructions included.

Product	Code
Optical Flat Cleaning and Care Kit	362555

Kemet Portable Hand 3 Lap Kit

Suited for flat lapping and polishing by hand. It contains three lapping plates, each with its own grade of Kemet Diamond Compound. This makes it possible to process many components in three stages, from lapping through to polishing. Each lapping plate is backed with anti-slip matting and aluminium backing plate.

Description & Contents	Code
Kemet Iron Lap Plate (for lapping), Kemet XP Lap Plate (for smoothing), Kemet Tin Lap Plate (for polishing) all 150mm diameter on an aluminium backing plate. 1 x 10g Kemet Diamond Compound Applikation Stick - 25 Micron. 1 x 10g Kemet Diamond Compound Applikation Stick - 8 Micron. 1 x 10g Kemet Diamond Compound Applikation Stick - 3 Micron. 1 x Kemet OS Lubricating Fluid. 1 x Aluminium case with Operating Instructions.	352206



Kemet Carbon Seal Lapping Kit

Kemet have developed a portable kit for dry lapping of carbon mechanical seals. The kit consists of a lapped aluminium substrate and 5 superfine abrasive discs. The specially designed discs allow carbon seals to be lapped without the need for any added loose abrasive. This alleviates loose abrasive impregnation into the carbon face.

Description & Contents	Code
300mm diameter Kemet lapping plate. Kemet portable case for ease of transport. Special polishing discs (Pack 5). Consumables to extend the life of the lapping discs	352565



Kemet Hand Lap Kits

Components lapped and/or polished by hand in minutes rather than hours. Ideal for components manufactured from ceramics, tungsten carbide, ni-resist etc. Kemet portable hand lapping kits are also ideally suitable for low volume production, when optimum surface finish is required, and where it is not economical to purchase a lapping or polishing machine.

Type	Plate (348mm dia)	Contents	Applikation Stick	Code
Type L Kit (Lapping)	Kemet Iron	1 x 10g Kemet Diamond Compound Applikation Stick.	25 Micron	352216
Type P Kit (Polishing)	Kemet XP	1 x Kemet OS Lubricating Fluid. 1 x Aluminium case with Operating Instructions.	3 micron	352208
Type SP Kit (Super Polishing)	Kemet XL		3 micron	352370



Pressure Relief Valve Lapping Kit

Incorrect lapping and or the use of improper equipment is a major contributor to seat leakage, which in turn leads to high emission rates and costs in loss of process. Kemet have produced a lapping kit that can be used on Tyco, Crosby, and Anderson Greenwood pressure relief valves.

Description & Contents	Code
15 Lapping / Polishing blocks, double sided (D through T2 orifice sizes). 1 x Applikator of 3 Micron Kemet Diamond Compound. 1 x Applikator of 14 Micron Kemet Diamond Compound. Bramet Silicon Carbide self adhesive papers. Grades 60, 120, 180, 320 Grit. Housed in strong plastic case (Weight approx 11.5 Kg).	352900



Ultrasonic Cleaning & Fluids

Although they are useful processes, lapping and polishing will always leave contaminants (abrasives, liquids, particles of the component material) on the parts when the process has finished.

Experience tells us that aqueous ultrasonic cleaning is the best solution for removing contamination from lapped and polished parts because the ultrasonic action is “searching” enough for complex parts, whilst at the same time gentle enough to not damage the flat lapped/polished surface. Even mirror polished surfaces can be cleaned in this way without degrading the polished finish.

Kemet have a full range of the most advanced ultrasonic cleaning equipment with new technology that assures maximum cleaning results whatever the condition within the tank. Ideal for multiple part cleaning, or validated part cleaning along with spray cleaning solutions for single part inspection.

For high volume production we can supply multi stage washing rinsing and drying systems, with or without handling systems, and fully enclosed, if required.



Free Ultrasonic Cleaning Trials

Before

Aluminium (Diamond lapping residue)

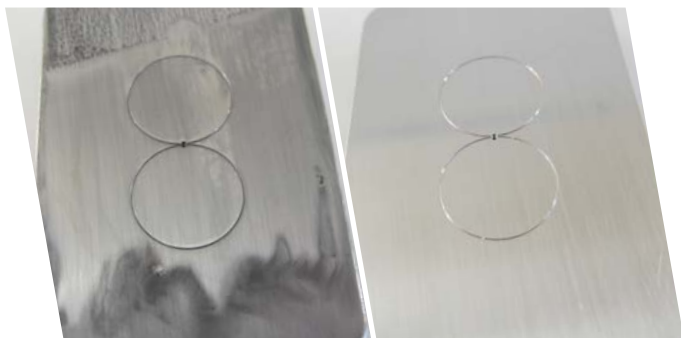

After

Before

Aluminium (Aluminium oxide lapping residue)

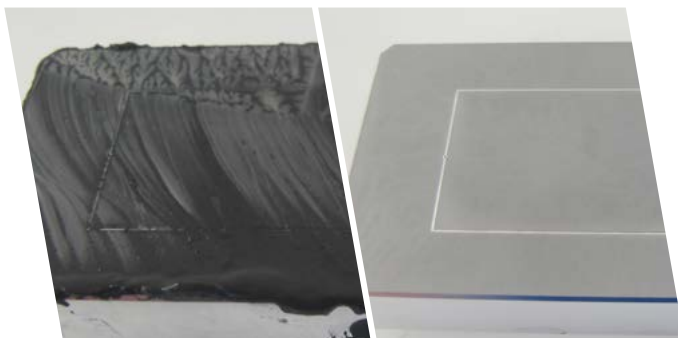

For more Cleaning case studies browse to <https://www.kemet.co.uk/blog/cleaning>

Ultrasonic Cleaning Fluids

Kemet are a distributor of NGL with more than 300 high performance formulations providing a solution to most cleaning challenges. The finest in biodegradable cleaning fluids, these are specially formulated concentrated detergents available in neutral, alkaline and acid types.

The detergents work by reducing surface tension, intensifying ultrasonic cavitation, dissolving and binding the contaminants that have been loosened by the ultrasonics.

- Free consultations and trials to adapt formulations to specific requirements and optimise cleaning processes.
- Environmentally aware process development to offer ecological solutions.
- Compatible with Kemet range of ultrasonic cleaners.
- Physiochemical and physical wastewater treatment systems to comply with environmental legislation.

Kemet recommend that any cleaning fluid should be tested on a sample of the component to be cleaned to ensure it does not damage the material and offer free trials to establish the optimum process.



For a full list of ultrasonic cleaners and cleaning fluids visit www.kemet-cleaning.co.uk or Kemet Cleaning catalogue

Dasty Industrial Degreaser

For hand cleaning, this product is extremely effective for thoroughly degreasing all mechanical parts as well as large surfaces and perfect for cleaning off lapping residue. Thanks to its ultra-concentrated formula, Dasty easily removes grease, mineral oil, scale, etc. and is biodegradable, safe for shipping and contains no ozone depleting chemicals.

Size	Code
1 Litre	362936
Box of 12	362962

- **Dasty can be used in diluted form in ultrasonic cleaning machines - contact Kemet for more information.**



Hand Cleaning Solutions

CO - 42 Cleaning Fluid

Designed for cold use and applied by spray, brush, cloth or full immersion, CO42 is a highly efficient degreasing fluid similar in performance to 1.1.1 Trichloroethane, but without the ozone depleting properties.

Size	Container	Code
450ml	Trigger Spray	302103
5 Litres	Metal	302102
25 Litres	Metal	302101
200 Litres	Metal	302105

C70 Solvent Cleaning Fluid

A versatile and highly efficient cleaning and degreasing fluid with a fast evaporation rate for removing grease, oil and residues from all metals and ceramics. Supplied in a pressurised container, complete with detachable extended spray tube for reaching into the most difficult areas, C70 contains NO ozone depleting substances.

Size	Container	Code
500ml	Aerosol	302114
500ml	Aerosols (Pk 12)	302115



- C70 and CO-42 are **NOT** approved for use at elevated temperatures or in ultrasonic cleaning machines.

Kemet Technical Centre



Lapping and Polishing Services

If your components require optimum flatness to perform to specification, if they are difficult to lap, or you have a particularly tight deadline to meet, Kemet's Sub Contract Service is the answer. We are renowned for our service, reliability and quality, and we specialise in fast turnaround times.

Our machines are equipped with both standard and special lapping plates to enable us to process most types of components. We are able to lap and/or polish components up to 530mm diameter (approx 21").

All work is returned with a Certificate of Conformity covering the generated surface finish and flatness, relative to the customer's drawing or specification.

Kemet Europe B.V. in The Netherlands, also offer lapping and polishing of components for companies who have high surface finish requirements, but don't have the necessary equipment.

Free Lapping Trials

Before

Medical Device Lapped & Polished

After



Before

Gate Valve Lapped

After

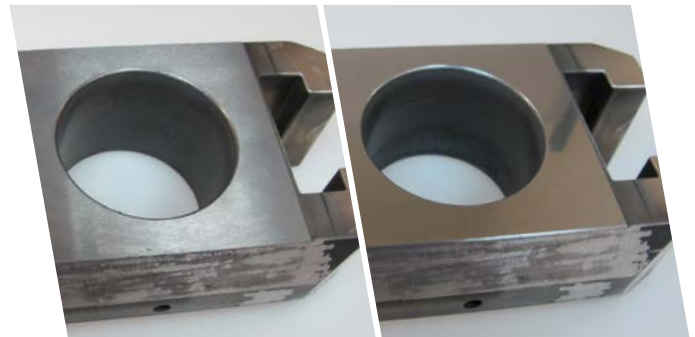

For more Lapping case studies browse to <https://www.kemet.co.uk/blog/lapping>



Research & Development Facilities

Our R&D and contract lapping centre in Singapore and Shenzhen offer the latest machines and equipment to process a wide variety of materials such; optical glasses, YAG materials, various filter glasses, Sapphire, Ceramics and much more.

Process Development

We regularly assist customers by developing new products and processes, utilising the very latest in precision flat lapping technology. Customers' samples are evaluated, free-of-charge. Comprehensive reports are issued covering all aspects of the process, including details of abrasive, lapping plate, workholding, inspection, cleaning and the likely consumable costs involved. Here are some of the materials we are able to process:

Acrylic	Ceramic	Gold	Silicon Carbide
Alloys	Chrome Plate	Graphite	Sintered Materials
Alumina	Cobalt Chrome	Inconel (Cobalt/Nickel)	Stainless steel
Aluminium	Compact Disc	Keronite (ceramic)	Steel
Aluminium Nitride	Concrete Cement	Molybdenum	Steel (Hard)
Anodised Aluminium	Copper	Nimonic Steel	Titanium
Beryllium Copper	Diamond Tools	Nickel	Tool Steel
Bone	Epoxy Resin	Piston Rings	Toughened Steel
Boron Carbide	Ferrite	Plastic	Tungsten carbide
Brass	Fibre Optic	Polyetherimide	Tungsten Copper
Bronze	Film Guide	Quartz	Vulcanised Fibre
Carbon	Gallium Arsenide	Sapphire	Zinc Selenide
Carbon Fibre	Germanium	Silicon	Zirconate (Lead) Titanate
Cast iron	Glass	Silicon Aluminium Alloy	

If a material does not appear in the list, please contact Kemet on **+44 (0)1622 755287**. All processed samples are returned with detailed technical process reports including detailed surface finishing measurements, free of charge.

Training

Tailor-made training courses are delivered regularly in our Technical Centre or at a customers' premises. On completion of a course, participants are awarded a certificate. Typical subjects are:

- Theory of lapping and polishing
- Setting up and operating machines
- Flatness control and measurement
- Surface finish measurement
- Product cleaning and inspection
- Types of abrasive
- Lapping plate types
- Workholding methods

Kemet After Sales Service and Support

Our expertise is available to you through our in-house technical specialists, a team of 5 Technical Representatives in the UK, and an extensive network of overseas Subsidiary Companies and Distributors.

Kemet provide continuous technical support for both prospective and current customers to ensure that any problems are correctly and quickly resolved.

Machine Repairs & Servicing

- Fully trained technical service engineers
- On-site repair service (Service contracts available)
- Safe Contractor accredited
- Process support



Flat Lapping Q&A

What is Lapping?

Lapping is a surface finishing process that improves surfaces that have previously been ground or fine turned. Lapping can produce many different types of finish, from a dull grey matt lap to a mirror polish, depending on the material being lapped, and the method of lapping.

Why do we need to Lap?

- To produce a fine surface finish
- To produce sealing surfaces
- To produce sharp cutting edges
- To produce flat stress free surfaces
- To produce a datum face
- To improve the wear resistant properties of surfaces

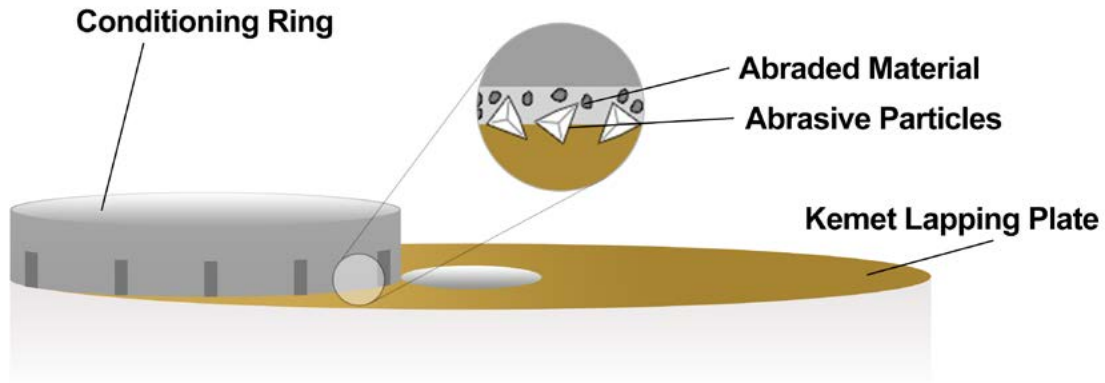

What is Conventional Lapping?

In conventional lapping, the abrasive (aluminium oxide or silicon carbide) is applied in a carrying vehicle (Lapping Oil) onto a hard surface such as cast iron. The particles cannot be pressed into the surface and be secured there, so they roll and move freely in all directions. They hammer small particles out of the sample surface, introducing deep deformations. This takes place because the free moving abrasive particle is not able to produce a real “chip” of the component surface. Conventional lapping produces only grey matt finishes.

What is Diamond Lapping?

Diamond lapping is a material removal method using fixed diamond abrasive particles which produce chips off the component material. The process of making chips with a sharp abrasive grain produces the lowest amount of deformation in the component while giving the highest removal rate. Diamond abrasive is pushed into the lapping plate surface, by a chamfer on the leading edge of the conditioning rings.

What is Polishing?

Polishing is often carried out after a lapping operation, to produce the ultimate in surface finish. Some of the common reasons for polishing are:

- To produce mirror surfaces
- To improve appearances
- To obtain the optimum sealing surfaces
- To optically measure flatness
- To improve electrical contact
- To improve the optical qualities of materials

What is Diamond Polishing?

Diamond Polishing uses the same mechanism as Diamond lapping. However by using successively small grain sizes of 8, 6 and 3 micron diamond, with softer Kemet plates and polishing pads with higher resilience, polishing can remove the deformations and scratches from lapping.

Want to Learn more? Kemet
Provide Custom Training for
Lapping & Polishing





Falling behind? Get lapping!



Components require optimum flatness and/or finish? Are difficult to lap? A tight deadline? Kemet provide a precision lapping and polishing service with a fast turnaround.

Renowned for reliability and quality, our facilities and expertise enable us to lap and polish most components and materials to a specific surface finish and flatness, all with a CoC to a given specification and precision cleaned in our Cleaning Technical Centre. Contact Kemet for a free quotation.

Kemet



Kemet International Ltd. Subsidiary Companies

Netherlands
Kemet Europe B.V

Singapore
Kemet Far East Pte Ltd

Japan / Korea
Kemet Japan / Kemet Korea

China
Kemet China Ltd

Malaysia
Kemet Precision (M) SDN BHD

Australia
Kemet Australia Pty Ltd

Kemet Products are available through a worldwide Network of Authorised Distributors in

Europe
Asia

Africa
Americas

Middle East
Australasia